

Goals:

The goal of this project is to provide you with an opportunity to apply your knowledge to solve an open-ended problem. The task is to design and build a machine that can autonomously navigate around the field and deliver construction materials to the correct locations.

Purpose:

The underlying purpose of this project is to give you experience in integrating all that you have learned in ME218 as well as your prior courses. The avenue through which you will gain this experience is the design and implementation of an autonomous mobile robot that can compete in a game of speed, skill and strategy against machines constructed by other teams from the class.

The Game:

The Technology in the Arts gallery put on by ME218A was successful beyond expectations, and has resulted in an influx of donors wanting buildings to put their names on. To keep up with demand, Stanford has decided to improve the rate of construction around campus by standardizing building materials and arranging to have those building blocks air-dropped at the various sites around campus. Stanford has developed a networked construction management system to manage routing and allocation of these air-dropped units, but needs Targeted Extremely Ballistic Universal Containerized Heavy Engineering Trucks (TREBUCHETS) to actually deliver the materials. To develop a prototype system, they have reached out to ME218B, which is where you come in. You will need to build TREBUCHETS that can retrieve construction materials, transport them to staging areas, and then deliver them (in a targeted, extremely ballistic way), to the construction sites.

Specifications

The Playing Field:

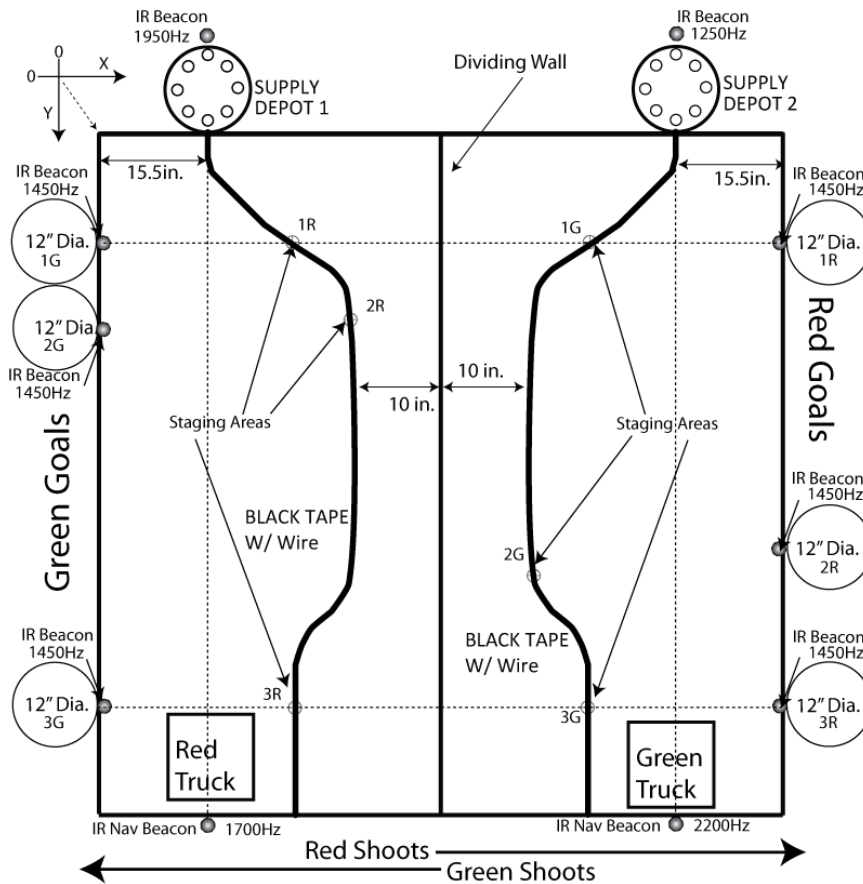

Fig. 1 The Playing Field

ME 218b Winter 2017 Project: Rapid Planned Assembly

Staging Area	Location
1R	2.298',1.193'
2R	3.000',2.105'
3R	2.298',6.700'
1G	5.807',1.193'
2G	5.157',5.140'
3G	5.807',6.700'

- Staging area locations are given in inches from the upper left corner of the field.
- Stanford's central campus (playing field) is an approximately 8'x8' area with exterior walls and center divider 3.5" tall.
- Each of the staging areas will be marked by a magnetic field modulated at changing frequencies as the campaign progresses.
- Your TREBUCHET will need to be able to sense the frequency of the magnetic field in order to prove that you are at the staging area.
- The check in procedure is documented in the Communications Protocol document that is an appendix to this project description.
- Modulated IR beacons will be mounted above each of the construction sites, the reload stations, and navigation stations, as shown in Fig. 1. The emitters of these beacons will be placed 12" above the surface of the campus.
- The construction sites are 5 gal Home Depot paint buckets located as shown in Fig. 1.
- A truck route leading through all of the staging areas will be marked by a 1" black tape line, as shown in Fig. 1. Beneath the black tape will be a wire carrying a 100mA current modulated at 20kHz.

The Targeted Extremely Ballistic Universal Containerized Heavy Engineering Truck (TREBUCHET):

- Your TREBUCHET must be a stand-alone entity, capable of meeting all specifications described in this document. Only NiCd battery power is allowed. No more than two 7.2V batteries may be used to drive the motors that transfer force to the ground.
- Each TREBUCHET must have a mechanism to designate the TREBUCHET as RED or GREEN.
- Each TREBUCHET must include a means to clearly indicate to the audience its RED/GREEN status.
- TREBUCHETs must be autonomous and un-tethered.
- The only parts of the TREBUCHET that may ever touch the playing field surface are wheels, ball transfers, or slippery supports used to balance the TREBUCHET.
- There must be a bumper surrounding the perimeter of your TREBUCHET extending for 2" vertically with its bottom edge exactly 1" ($\pm 1/16"$) from the floor.
- Your TREBUCHET must be fully contained within a 1' cube at the beginning and end of the game.
- Each TREBUCHET may carry a maximum of 5 CONstruction Widgets (COWs) (foam balls) at any time. Each TREBUCHET will start a round loaded with up to 3 COWs, as desired by your team.
- When deployed, the COWs must exit your TREBUCHET with an above-horizontal trajectory, land no more than 12 feet from the TREBUCHET and reach a peak height of no more than 8' above the floor of the playing field.
- Each TREBUCHET must carry an easily accessible switch. The purpose of the switch will be to cut power to the TREBUCHET in case of a software or hardware malfunction.
- Each TREBUCHET must be constructed as part of ME218b. It may not be based on a commercial or

ME 218b Winter 2017 Project: Rapid Planned Assembly

otherwise pre-existing platform.

- Any exterior corners on the TREBUCHET must have a radius of at least 1/4".
- To stay within the donors' limitations on overhead costs, you are limited to an expenditure of **\$200.00/team** for all materials and parts used in the construction of your project. Materials from the lab kit or the Cabinet Of Freedom do not count against the limit; all other items count at their Fair Market Value.
- Each TREBUCHET must provide a clearly visible indicator when it thinks that construction is in progress. This indicator should be activated when the TREBUCHET determines that the building process has started and be de-activated when the construction status indicates the end of building process.
- Only the supplied motors may be used to drive anything that transfers force to the ground.

The Supply Depots:

SUPPLY DEPOT DIMENSIONS

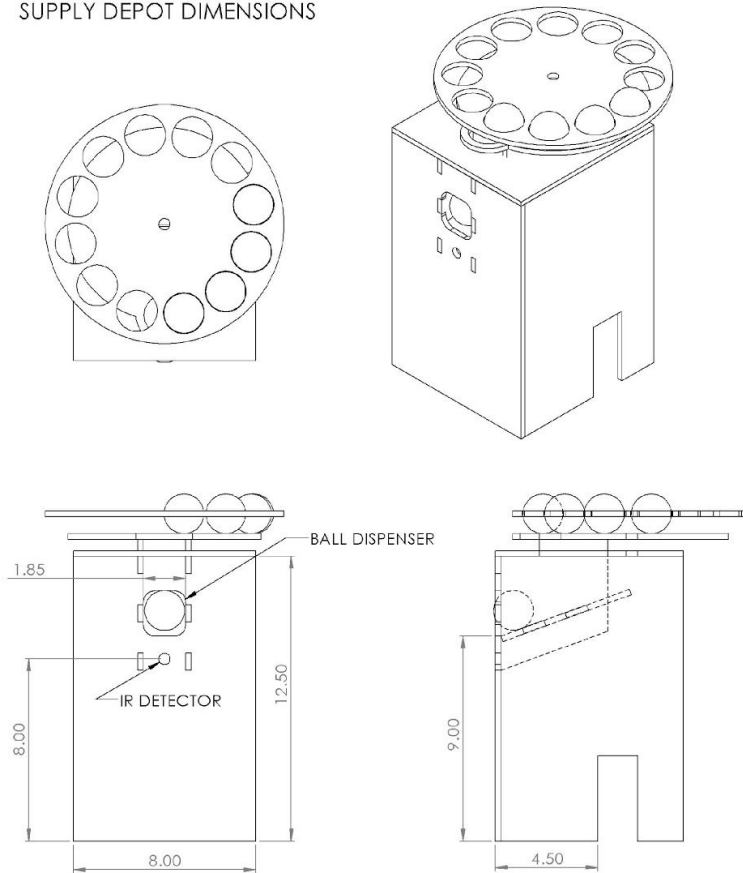

- The supply depot will deliver a single COW each time its IR detector receives a series of 10 pulses with a 10ms (± 0.1 ms) on time and a 30ms (± 0.1 ms) off time. While delivering these pulses the TREBUCHET must also illuminate a visible LED that is clearly visible to any observer.
- The time from request to physical delivery of a COW may be as much as 3 sec. During this time, the TREBUCHET may not request another COW.
- The IR detector at the supply depot will be mounted at a height of 8" off the playing surface.

The Logistic Operations Coordinator:

- The Logistic Operations Coordinator (LOC) will provide information to the TREBUCHET about the status of construction and provide for communications with the Construction Manager (field infrastructure) to verify movement of TREBUCHETs and COWs.

ME 218b Winter 2017 Project: Rapid Planned Assembly

- The LOC will communicate with your robot over a 4-wire SPI bus.
- The LOC will be recognized by and communicate wirelessly with the Construction Manager, so it should be mounted where it will have good radio reception.
- A complete description of the Logistic Operations Coordinator, from both an electrical and protocol standpoint, is included in an appendix that accompanies this project description.

The Construction Cycle:

- The game is a head-to-head contest among two TREBUCHETs as they navigate around the playing field following directions from the LOC and shoot at the construction site that has been opened by the field infrastructure.
- Each construction cycle will last for 2:18 (Min:Sec).
- At the end of 2:18, the TREBUCHET with the greatest number of balls in their buckets is the winner.
- The construction cycle will begin when a query to the LOC indicates that the game state has changed from "Waiting for Start" to "Constructing".
- Once the game has begun, the LOC will be queried to identify the next staging area. Once a player has navigated to the staging area and proved its location through the protocol described in the appendix, one of the construction areas will be opened for shooting and that information made available through the LOC.
- Once a construction area is opened for shooting, it will remain open for 20 seconds or until a COW is delivered. At that time, the player must poll the LOC for a new staging area and repeat the process.
- During the last 18 seconds of the round, all construction areas will be opened and no further check in with the field infrastructure is required to shoot.

Rules:

- No solder-less breadboards (proto-boards) are permitted in the final project.
- Each TREBUCHET must start and remain in one piece during the round. Any locomotion of the TREBUCHET should cause all parts of the TREBUCHET to move.
- Your TREBUCHET may not **IN ANY WAY** alter the condition (e.g. mar the walls or the floor) of the playing field or the foam balls. Before you choose your wheel material and again before you place your TREBUCHET on the field for the first time, borrow a material sample from the TAs and test to be sure that your wheels will not mar the floor material.
- Intentional jamming of your opponent's senses or violation of the communications protocol is prohibited.

Safety:

- The TREBUCHET should be safe, both to the user and the spectators. The teaching staff reserves the right to disqualify any TREBUCHET considered unsafe. This also applies during testing, so keep the TREBUCHET velocity and shooting velocity low enough so as not to cause problems.
- TREBUCHETs must be stable in the presence of a 30MPH wind.
- No part of the machine may become ballistic. The foam balls are not actually part of your machines.
- All liquids, gels and aerosols must be in three-ounce or smaller containers. All liquids, gels and aerosols must be placed in a single, quart-size, zip-top, clear plastic bag. Each TREBUCHET can use only one, quart-size, zip-top, clear plastic bag.
- Red, Green, and Blue shells are prohibited. Any Banana peels must stay within the confines of your TREBUCHET at all times.
- TREBUCHETs may alter the space-time continuum only during the public presentations.

Checkpoints

Design Review:

During the day on **02/14/17** we will conduct design reviews. A few teams at a time will meet with the teaching staff to present their ideas and get feedback on their proposals. Each group should prepare a **few** sheets of paper showing your idea(s). The focus should be on the overall design and how you are tackling what you think are the critical subsystems. These should be scanned into a no-frills PowerPoint file for projection. Bring a laptop and the necessary adapters to connect your laptop to either a VGA or HDMI connector for the projector. You will have 10 minutes to walk us through your ideas. **No code, no state diagrams, no circuits.** The members of the other teams, the teaching staff, and coaches will be on hand to hear about your ideas and provide feedback and advice.

A spider conducts operations that resemble those of a weaver, and a bee puts to shame many an architect in the construction of her cells. But what distinguishes the worst architect from the best of bees is this, that the architect raises his structure in imagination before he erects it in reality.

Karl Marx

First Checkpoint:

On **02/17/17**, you will turn in a set of Protel schematics, textual descriptions and software design documentation (including refined statechart) that describes the state of the design at that point in time. The designs need not be tested at this point, but must include designs to address all of the major subsystems. It must be turned in as soft copy. Only one team member needs to submit your checkpoint.

*When we mean to build,
We first survey the plot, then draw the model*

William Shakespeare

Second Checkpoint:

On **02/22/17**, you must demonstrate your un-tethered, motorized platform moving under autonomous software control. Your platform must be able to drive across the campus and back under software control.

*Ah, to build, to build!
That is the noblest of all the arts.*

Henry Wadsworth Longfellow

Third Checkpoint:

On **02/25/17**, you must demonstrate the integration of the LOC with your mobile platform and your robot's ability to communicate with the LOC to exercise all of the LOC's capabilities. Evidence of achieving this functionality will be demonstrated by driving to the staging area indicated by the LOC and successfully completing the handshake to open a construction site while starting from an arbitrary location and upon initiation of an "Construction Active" status from the LOC.

Therefore when we build, let us think that we build forever.

John Ruskin

Fourth Checkpoint:

On **03/01/17**, you must demonstrate your robot's ability to 1) orient to the construction site (bucket) and shoot a COW at the bucket, 2) navigate to a specific staging area and successfully check in.

Architecture and psychology suddenly become very close.

Jacques Herzog

Project Preview:

At the Project Preview on **03/05/17**, each TREBUCHET must demonstrate (in an integrated form) 1) the ability to move around the Stanford campus under software control and 2) the ability to communicate with the LOC and 3) the ability to orient and shoot at the construction site. This will be tested by communicating an "Construction Active" status followed by the TREBUCHET proceeding to at least 2 staging areas, requesting a destination construction site and successfully delivering construction materials to those sites.

Life is chaotic, dangerous, and surprising. Buildings should reflect that.

Frank Gehry

Grading Session:

During the **grading session on 03/07/17** each TREBUCHET will be required to demonstrate a complete construction cycle including reloading. If your TREBUCHET fails at its first attempt to demonstrate its ability, it must then demonstrate the ability two times in succession at its next attempt. These increases continue after repeated failed attempts to a maximum of 4 required successive demonstrations. This evaluation will take place with only a single TREBUCHET on the course. Evaluation for grading purposes will occur only during these sessions. At the time of the grading session, you must submit a copy of your Keil Project folder that you run during the grading session to your Reports folder for archiving.

Architecture is frozen music.

Johann Wolfgang von Goethe

Public Presentation:

Will take place on **03/08/17** starting at 7pm in the Peterson Atrium.

There can be little doubt that in many ways the story of bridge building is the story of civilization.

Franklin D Roosevelt

Report:

Draft due on **03/13/17** at 4:00pm. Final version with revisions due by 5:00pm on **03/17/17**.

We shape our buildings, thereafter they shape us.

Winston Churchill

Evaluation

Performance Testing Procedures:

One or more of the team members will operate the TREBUCHETs during the performance evaluation. A competition among the class's TREBUCHETs will take place after the performance evaluation.

Performance Evaluation:

Performance evaluation will take place twice during the project duration, at the Project Preview and at the Grading Session. Everyone will participate at this level.

The Competition:

On the night of the public presentations, a tournament will be held. **Performance during the tournament has no impact on your grade.**

Grading Criteria:

- Concept (10%)** This will be based on the technical merit of the design and coding for the machine. Included in this grade will be evaluation of the appropriateness of the solution, as well as innovative hardware, software and use of physical principles in the solution.
- Implementation (15%)** This will be based on the prototype displayed at the evaluation session. Included in this grade will be evaluation of the physical appearance of the prototype and quality of construction. We will not presume to judge true aesthetics, but will concentrate on craftsmanship and finished appearance.
- Checkpoint Performance (10%)** Based on demonstrating the required functionality at the checkpoints.
- Preliminary Performance (10%)** Based on the results of the performance testing during the Project Preview.
- Performance (20%)** Based on the results of the performance testing during the Grading Session.
- Coaches Evaluation (5%)** Evaluation by your coach: did you make use of their input before the design review and during the course of the project.
- Report (20%)** This will be based on an evaluation of the written report. It will be judged on clarity of explanations, completeness and appropriateness of the documentation. The report should be in the form of a web site and must include schematics, pseudo-code, header & code listings, dimensioned sketches/drawings showing relative scale, a complete Bill-of-Materials (BOM) for the project as well as a 1

ME 218b Winter 2017 Project: Rapid Planned Assembly

page description of function and a “Gems of Wisdom for future generations of 218ers” page. The web-site must be submitted as a single **Zip** file (The zipping software (7-zip) is installed on all the workstations in the lab). The only file types in your final report should be HTML (including style sheets if you choose), JPEG or other viewable image files and PDF files. Schematics should be PDF files, **not** bitmaps (PNG, JPEG, GIF, etc.). A reasonable resolution bitmap place-holder with a link to a PDF is the best solution to readability. Do not simply place a link to the PDF of the schematic without a viewable preview on the web page. Do not include .doc, .docx, .xls, .xlsx or other files that require opening a separate application outside of the browser. **Do not embed video files directly** into your site. If you want to include video, link to a YouTube or other video sharing site. In addition, if your website is hosted, you should include a text file with the URL to your site. It is critical that your report be in the Reports folder on time so that the peer reviewing team will have an adequate opportunity to review it before class the following day. Final versions of the reports, incorporating the review comments are due (also in the form of a single zip file) by 5:00pm on 03/17/17. Also include a plain text document with the URL of a live version of your report site. The front page of your site must be in a file called index.html at the root folder of the web site. Test your zip-file by unzipping it into an empty folder. Once unzipped, you should be able to view the entire site starting from the index.html file. Make sure to test all of your links before submitting. If we can’t simply unzip it and read it on our machines, then we can’t grade it.

- Report Review (10%)** These points will be awarded based on the thoroughness of your review of your partner team’s report. Read the explanations, do they make sense? Review the circuits, do they look like they should work?
- Housekeeping** Based on the timely return of SPDL components, cleanliness of group workstations as well as the overall cleanliness of the lab. No grades will be recorded for teams who have not returned or paid replacement costs for the items borrowed from the SPDL, including but not limited to Tiva, power supplies, logic analyzer, tools...

Team Organization

While it may be tempting (and more efficient) to organize your teams around specialists who handle, for example, communications, sensing, motion, etc. I believe that in the long run this will be a mistake. I have heard from many 218 alumni who did this and reported that they were sad that they had because they didn’t get, for example, communications experience. I would like to encourage you to remember that, first and foremost, the purpose of the project is to enhance your learning of the material. An organization that deeply involves all of the team members in the details of the design, implementation and debugging of all subsystems will not only provide a better learning experience, it will also prevent you from getting hung up during the integration and testing phase because the “expert” on that subsystem is not available.

Purpose:

The primary purpose of the Logistic Operations Coordinator (LOC) is to act as a gateway to the field infrastructure to allow your TREBUCHET to request information about the state of the Construction Cycle and determine the currently active staging area and construction site.

Interface Connection

Connector:

The connector of the LOC is a 6-pin keyed Molex connector.

Pinout:

Pin	Name/Function
1	+3.3V (@ 100mA) / Power to the LOC (V_{dd})
2	SDI / Serial Data Into the LOC
3	SDO / Serial Data Out of the LOC
4	SCK / Serial Clock
5	SS / active low select line for the LOC with on-board pull-up to +3.3V
6	GND / Ground reference for the LOC

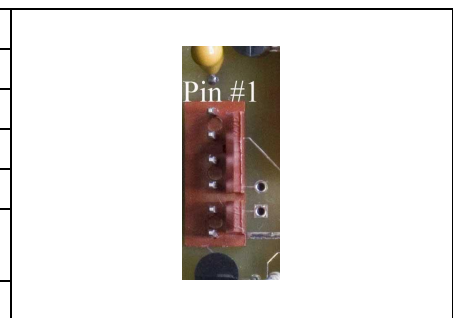

Electrical Specifications

Parameter	Min.	Max	Units
V_{iH}	$V_{dd} * 0.65$		V
V_{oH}	$V_{dd} - 0.4$		V
V_{iL}		$V_{dd} * 0.35$	V
V_{oL}		0.4	V
I_{iH}, I_{iL}		± 1	μA
I_{oH}	-20		μA
I_{oL}	20		μA
All Specifications at $V_{dd} = 3.3V$			

Byte Transfer Specification

The Logistic Operations Coordinator uses a synchronous serial signaling method to transfer data into and out of the LOC. The signaling method is compatible with SPI communications, with the LOC operating as a slave device on an SPI network. The \overline{SS} line must be lowered (asserted) to begin an 5-byte (40 bit) transfer and raised at the completion of the 5-byte transfer. The \overline{SS} line must remain de-asserted for a minimum of 2ms between transfers. The SDO line represents the serial data out of the LOC, while the SDI line represents serial data into the LOC.

The relationships between the four lines involved in the transfer of a byte are shown in the figure & table below:

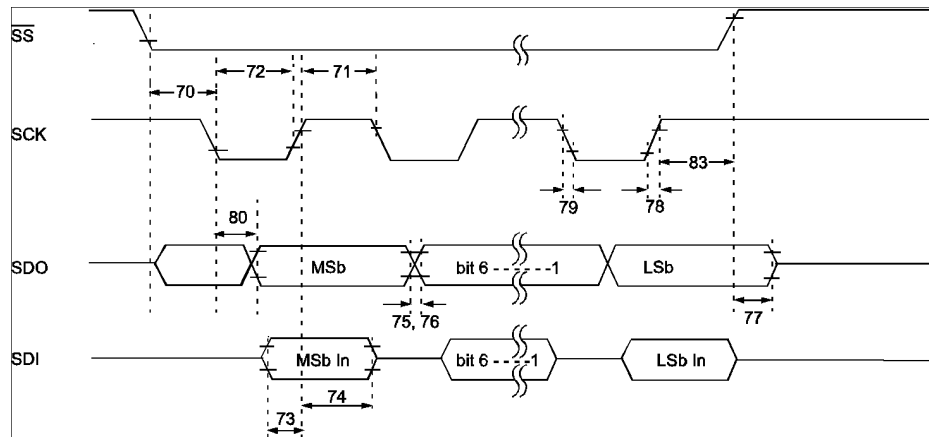

Param No.	Symbol	Characteristic	Min	Typ	Max	Units	Conditions
70*	TssL2scH, TssL2scL	SS↓ to SCK↓ or SCK↑ input	Tcy ^a	—	—	ns	
71*	TscH	SCK input high time (Slave mode)	Tcy + 20	—	—	ns	
72*	TscL	SCK input low time (Slave mode)	Tcy + 20	—	—	ns	
73*	TdIV2scH, TdIV2scL	Setup time of SDI data input to SCK edge	100	—	—	ns	
74*	Tsch2dIL, TscL2dIL	Hold time of SDI data input to SCK edge	100	—	—	ns	
75*	TdoR	SDO data output rise time	3.0-5.5V	—	10	25	ns
			2.0-5.5V	—	25	50	ns
76*	TdoF	SDO data output fall time	—	10	25	ns	
77*	TssH2doZ	SS↑ to SDO output high-impedance	10	—	50	ns	
78*	TscR	SCK output rise time (Master mode)	3.0-5.5V	—	10	25	ns
			2.0-5.5V	—	25	50	ns
79*	TscF	SCK output fall time (Master mode)	—	10	25	ns	
80*	Tsch2doV, TscL2doV	SDO data output valid after SCK edge	3.0-5.5V	—	—	50	ns
			2.0-5.5V	—	—	145	ns
83*	Tsch2ssH, TscL2ssH	SS ↑ after SCK edge	1.5Tcy + 40	—	—	ns	

* These parameters are characterized but not tested. ^aTcy = 33μS

Byte Level Protocol Specification

Common Byte Format:

Exchanges between the Logistic Operations coordinator (LOC) and your TREBUCHET take place with five successive bytes being exchanged. The first byte from the TREBUCHET to the LOC is the actual command. The value returned from the LOC during this transfer will be 0x00, but has no meaning. The values sent to the LOC as the second through fifth bytes of the sequence should always be 0x00. The meanings of the values returned by the second through fifth byte transfers will be the results from the command byte.

TREBUCHET to Logistic Operations Coordinator Bytes:

The meaningful values for the command bytes from the TREBUCHET to the Logistic Operations Coordinator are shown in the following table:

Command	Meaning
0b1100 0000	Return the status of the Construction Cycle.
0b1000 iiii	Report a measured staging area frequency.
0b0111 0000	Query for new response ready.

In the above message, iiii is a 4 bit number identifying the current frequency measured at the staging area (See [Codes for Frequency of the Magnetic Field at a Staging Area](#), below). Making a Report of a staging area's frequency may take significant time (up to hundreds of ms) to complete.

Logistic Operations Coordinator Documentation

Logistic Operations Coordinator to TREBUCHET Bytes:

The values and meanings of the response bytes returned by the Logistic Operations Coordinator are shown in the following table:

Command	Response Bytes	Description of meaning
0b1100 0000	0xFF, SB1, SB2, SB3	SB1 = Status Byte 1, SB2 = Status Byte 2, SB3 = Status Byte 3
0b1000 iiii	0xFF, 0x00, 0x00, 0x00	The Report of a staging area's frequency. This command takes significant time to complete. After issuing this Report, you must issue repeated Query commands until the LOC returns a Response Ready status. Allow at least 200ms between successive Reports. Subsequent Reports without an intervening successful Query response will be ignored and not result in further Reports being forwarded to the Construction Manager.
0b0111 0000	0xFF, RR, RS, 0x00	RR = Response Ready Byte, RS = Report Status Byte

Status Byte 1

7	6	5	4	3	2	1	0
CSG	GS02	GS01	GS00	CSR	RS02	RS01	RS00

Field Name	Description
CSG	Check-in(0)/Shoot(1) for Green
Green Goal Active Status (GS02, GS01,GS00)	0,0,0 = None 0,0,1 = Goal#1/Staging Area #1 0,1,0 = Goal#2/Staging Area #2 0,1,1 = Goal#3/Staging Area #3 1,x,x = All Goals
CSR	Check-in(0)/Shoot(1) for Red
Red Goal Active Status (RS02, RS01,RS00)	0,0,0 = None 0,0,1 = Goal #1/Staging Area #1 0,1,0 = Goal #2/Staging Area #2 0,1,1 = Goal #3/Staging Area #3 1,x,x = All Goals

Status Byte 2

7	6	5	4	3	2	1	0
unused	unused	GS5	GS4	GS3	GS2	GS1	GS0

Field Name	Description
Current Green Score (GS5-GS0)	Number of Goals scored by Green Side

Status Byte 3

7	6	5	4	3	2	1	0
GS	unused	RS5	RS4	RS3	RS2	RS1	RS0

Field Name	Description
Game Status (GS)	0 = Waiting for Start 1 = Construction Active (Constructing)
Current Red Score (RS5-RS0)	Number of Goals scored by Red Side

Logistic Operations Coordinator Documentation

Response Ready Byte

7	6	5	4	3	2	1	0
Response Ready Status							

Field Name	Description
Response Ready Status	0x00 = Response not ready 0xAA = Response ready Response Ready only returned once per Report If a response is not ready, then the Report Status Byte will be 0x00

Report Status Byte

7	6	5	4	3	2	1	0
ACK1	ACK0	unused	unused	LOC3	LOC2	LOC1	LOC0

Field Name	Description
Acknowledge (ACK1, ACK0)	0,0 = ACK 1,0 = Inactive 1,1 = NACK
Location (LOC3-LOC0)	4-bit number indicating the location of the staging area or goal. For the number to location correspondence, see Codes for Locations of the Staging Areas , below.

In response to a Report of a staging area frequency, a reply of

ACK	Will only occur in response to a Report if the reported frequency is currently active at a staging area and that location is the active staging area for check in.
NACK	Will occur in response to a Report if the reported frequency is not currently active at a staging area.
Inactive	Will occur if the frequency is measured correctly, but the corresponding staging area is not active for check ins. In this case, the LOC information is for the staging area with the measured frequency

Query the Status of the Game:

To query the game status, send a byte of 0xC0 to the LOC followed by 4 bytes of 0x00. The LOC will process the query and during the four 0x00 bytes of the exchange will return 0xFF, followed by the three status bytes as described above.

Proving Your Location:

To successfully open a construction site for delivery, a TREBUCHET must prove that they actually occupy the correct staging area. That proof is demonstrated by successfully executing two correctly formatted Report commands with no intervening unsuccessful Report commands. After the first Report, the Construction Manager will mark the staging area as being in a transaction sequence and change the frequency of the requested staging area. To complete the process of opening a construction site, the TREBUCHET must issue a second Report with the new frequency. After this, second, successful request, the Construction Manager will open a construction site and illuminate its IR beacon. Which construction site was opened will be indicated in the LOC field of the second successful request. The result from a subsequent Status request will also indicate the active goal and show it as active for shooting. It will continue to indicate as active for shooting until either a shot is successfully made or 20 seconds expires. After either of these conditions is met, the Status result will indicate the next active staging area.

Codes for Frequency of the Magnetic Field at a Staging Area:

Code	0000	0001	0010	0011	0100	0101	0110	0111
Period (µs)	1333	1277	1222	1166	1111	1055	1000	944
Code	1000	1001	1010	1011	1100	1101	1110	1111
Period (µs)	889	833	778	722	667	611	556	500

Codes for Locations of the Staging Areas & Construction Sites:

Code	0001	0010	0011
Location	1R	2R	3R
Code	0100	0101	0110
Location	1G	2G	3G

Power on and Reset Behavior:

Initially, after power on or a reset, the Logistic Operations Coordinator will return 0xFF from any query until such time as the Logistic Operations Coordinator is internally initialized.

Command Timing:

The interval between two successive transfers from TREBUCHET to Logistic Operations Coordinator should be at least 2ms. The \overline{SS} line must remain high for a minimum of 2ms between successive transfers.

Invalid Command Bytes:

If the Logistic Operations Coordinator receives a command byte not listed in the table, it will respond to the invalid command byte by queuing a series of 0xFF bytes to be returned to the TREBUCHET.

Sample Byte Sequences:

In the communication sequence diagrams shown below, there are 3 columns. The left column represent your TREBUCHET. The Middle column represents the LOC and the right column represents the Construction Manager. The Diagrams are read top to bottom to follow a conversation between the TREBUCHET and the LOC and between the LOC and the Construction Manager.

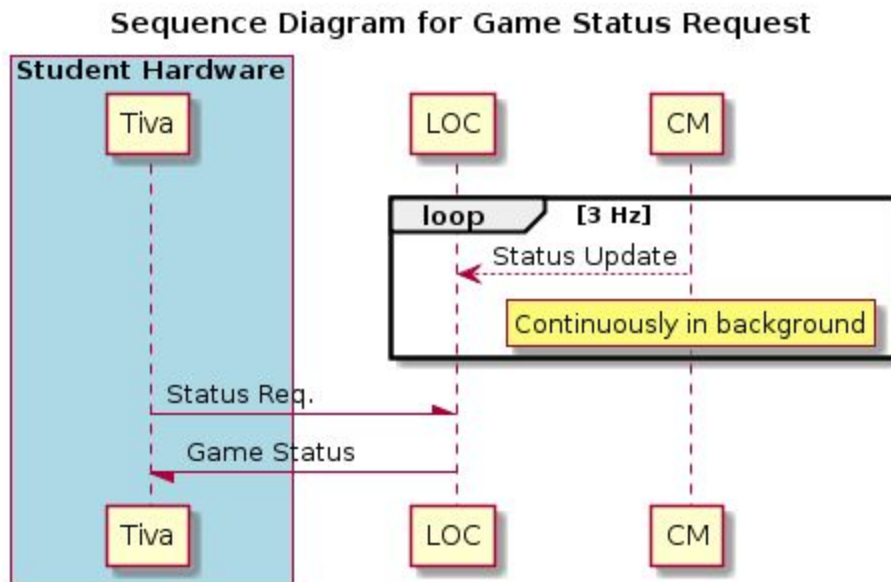

The Game Status will include an indication of the Staging Area that the TREBUCHET should move to for shooting instructions.

Sequence Diagram for Report Exchange

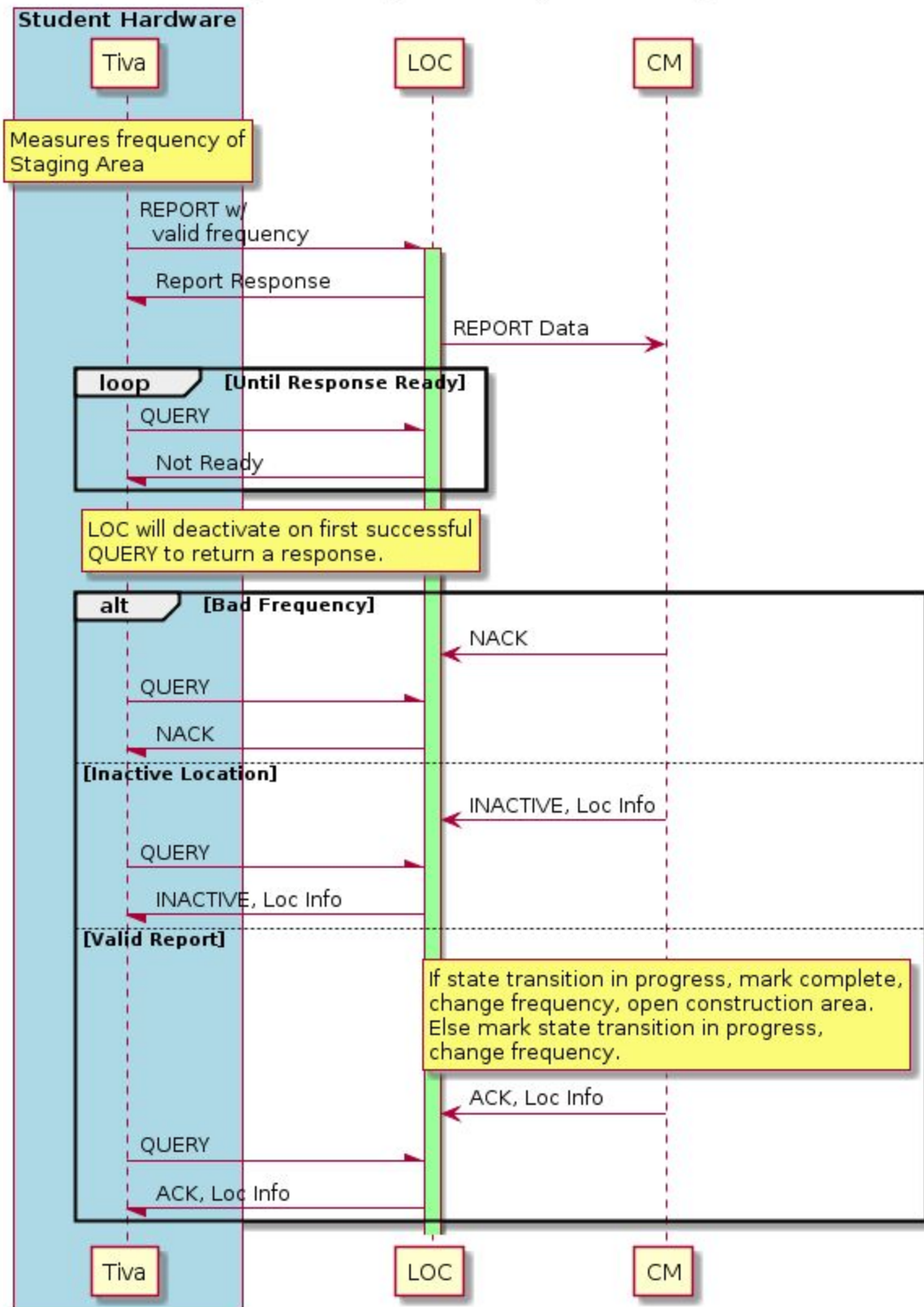

To complete opening a construction site for shooting, this sequence must be repeated a second time. The Loc Info returned at the end of that second sequence will be the construction site that was opened for shooting.

Physical Specifications

Dimensions:

The Logistic Operations Coordinator dimensions are 2" x 3" x 1".

Revision History:

Version	Date	Description
R 1.0	9 Feb 2017	First published revision